

* Includes blade, fishtail point, shock spring, shock top, & hardware.

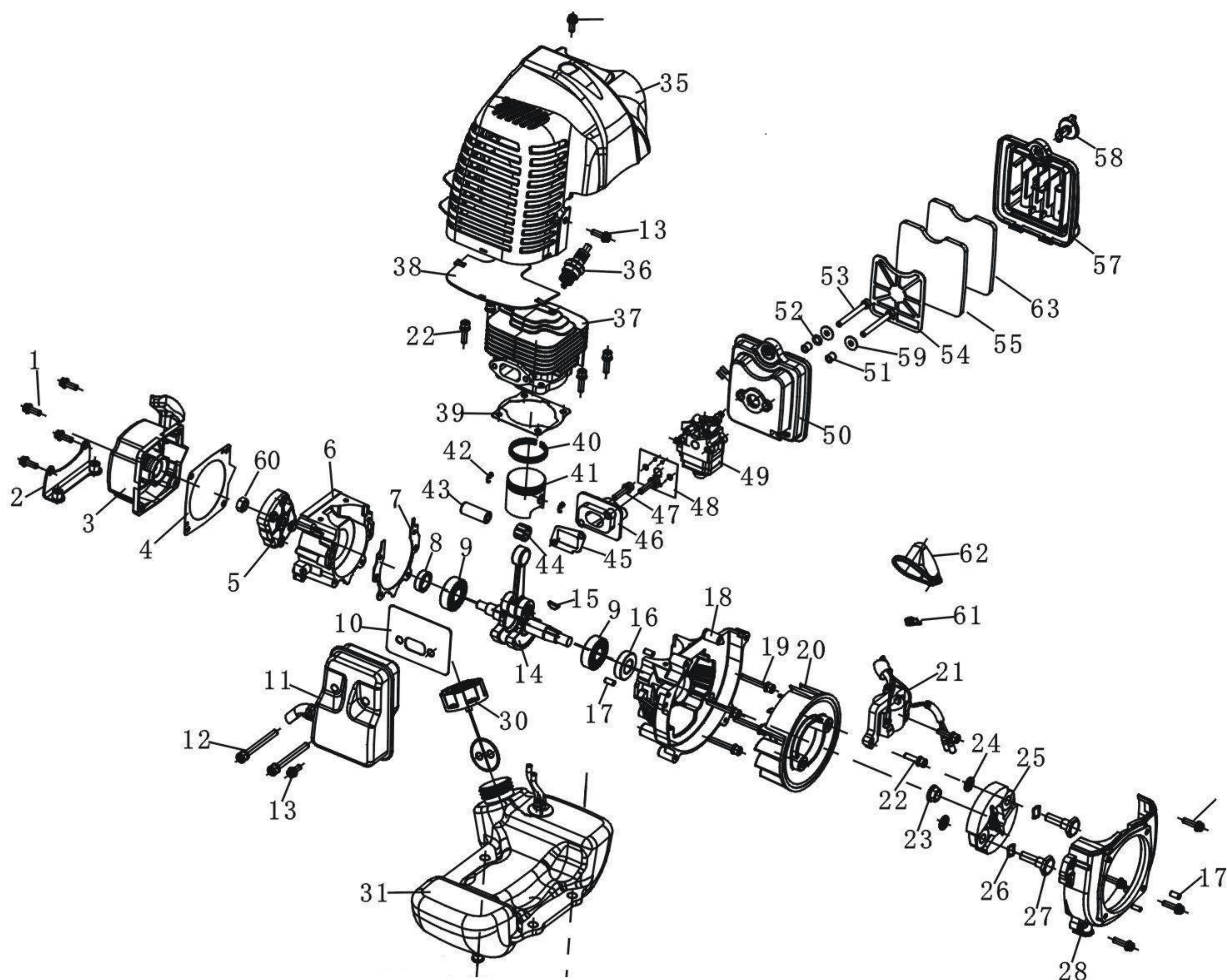

PARTS LIST OF 2-STROKE ENGINE

序號	Name
1	M5X20 SCREW
2	TANK SUPPORT
3	STARTER
4	AL.GASKET
5	PULLEY
6	LEFT CASE
7	CASE GASKET
8	OIL SEALING 12×22×7
9	BEARING
10	MUFFLER GASKET
11	MUFFLER
12	M6 SCREW
13	M5 SCREW
14	CRANKSHAFT
15	SEMI KEY
16	OIL SEALING 15X30X7
17	PIN
18	RIGHT CASE
19	M5X35 SCREW
20	FLY WHEEL
21	IGNITION COIL
22	M5 SCREW
23	M5 NUT
24	GASKET
25	CLUTCH
26	WASHER
27	CLUTCH SCREW
28	SIDE COVER
29	M5 SCREW
30	FUEL CAP
31	FUEL TANK

序號	名稱	Name
32		
33		
34		
35		CYLINDER COVER
36		SPARK PLUG
37		CYLINDER
38		BAFFLE
39		CYLINDER GASKET
40		PISTON RING
41		PISTON
42		PISTON CLIP
43		PISTON PIN
44		NEEDLE BEARING
45		MANIFOLD GASKET
46		INTAKE MANIFOLD
47		M5 SCREW
48		CARB. GASKET
49		CARBURETOR
50		AIR FILTER BASE
51		BUSHER
52		WASHER
53		M5X55 SCREW
54		GASKET
55		AIR ELEMENT
57		AIR COVER
58		AIR FILTER SCREW
59		WASHER
60		M8 NUT
61		SPARK SPRING
62		CAP
63		AIR ELEMENT